

# LK HydronicGroup H 125

## 865 DN 25



### TECHNICAL DATA

Voltage	230 VAC 50/60 Hz
Power consumption	10-75 W depending on pump speed
Working temperature	Min. 5 °C/Max. 100 °C
Ambient temp.	Min. 5 °C/Max. 58 °C
Max. working pressure	1,0 MPa (10 bar)
Media	Water - Glycol mixture max. 50%
Thread standard	Rp - female thread, G - male thread
Circulating pump	Wilo Para Z ku 15-130/8-75/SC
Material, valve body	Brass EN 12165 CW617N
Material, insulation	Expanded Polypropylene EPP

LK 865 HydronicGroup H 125 DN 25 is a complete unit for hot water circulation.

LK 865 HydronicGroup H 125 DN 25 comprises a highly efficient circulation pump, a mixing valve, cross, insulation, two thermometers, connection kit and three check valves.

The LK 551 HydroMix mixing valve has a thermostatic element that regulates the supply of both cold and hot water to the desired temperature. The valve has an anti-scald function that closes for incoming hot water if the cold water supply ceases.

### TECHNISCHE DATEN

Nennspannung	230 VAC 50/60 Hz
Leistungsaufnahme	10-75 W abhängig von Pumpendrehzahl
Arbeitstemperatur	Min. 5 °C/Max. 100 °C
Umgebungstemperatur	Min. 5 °C/Max. 58 °C
Max. Arbeitsdruck	1,0 MPa (10 bar)
Flüssigkeit	Wasser - Glykol max. 50%
Gewindenorm	Rp - Innengewinde, G - Aussengewinde
Umwälzpumpe	Wilo Para Z ku 15-130/8-75/SC
Material, Gehäuse	Messing EN 12165 CW617N
Material, Isolierung	Expandiertes Polypropylen EPP

Die LK 865 HydronicGroup H 125 DN 25 ist eine komplette Einheit für die Warmwasserzirkulation.

Die LK 865 HydronicGroup H 125 DN 25 besteht unter anderem aus einer hocheffektiven Zirkulationspumpe, einem Mischventil, Kreuz, zwei Thermometer, Verschraubungssatz, und drei Rückschlagventilen.

LK 551 HydroMix hat einen thermischen Einsatz zur Regelung der Warmwassertemperatur. Es regelt sowohl die Heißwasser- als auch die Kaltwasserzufuhr um die gewünschte Temperatur zu erreichen. Das Ventil hat einen Verbrühungsschutz, der den Zufluss von heißem Wasser bei Ausfall der Kaltwasserzufuhr unterbricht. Nebenversorgungsleitung gewünscht wird.

### DONNÉES TECHNIQUES

Tension nominale	230 VAC 50/60 Hz
Puissance maxi chaudière	10-75 W suivant position circulateur
Température de service	Min. 5 °C/Max. 100 °C
Température d'ambiance	Min. 5 °C/Max. 58 °C
Pression de service max.	1,0 MPa (10 bar)
Fluide	Eau - Glycol max. 50%
Filetage standard	Rp - filetage femelle, G - filetage mâle
Circulateur	Wilo Para Z ku 15-130/8-75/SC
Matériau, corps de vanne	Laiton EN 12165 CW617N
Matériau, isolation	Polypropylène Expandé EPP

LK 865 HydronicGroup H 125 DN 25 est un groupe de pompes complet pour la circulation de l'eau chaude.

LK 865 HydronicGroup H 125 DN 25 comprend entre autres une pompe de circulation très efficace, une valve de dérivation, des croix, de l'isolation, deux thermomètres, un ensemble de raccords et trois clapets anti-retour.

La vanne de mélange LK 551 HydroMix est dotée d'un élément thermique qui régule l'arrivée de l'eau froide et chaude pour obtenir la température souhaitée. La vanne a une protection anti-brûlure qui se referme devant l'arrivée d'eau chaude si l'arrivée de l'eau froide devait s'arrêter.

**DATI TECNICI**

Voltaggio	230 VAC 50/60 Hz
Consumo	10-75 W secondo la velocità della pompa
Temperatura di esercizio	Min. 5 °C/Max. 100 °C
Temperatura ambiente	Min. 5 °C/Max. 58 °C
Pressione massima di esercizio	1,0 MPa (10 bar)
Fluidi	Acqua. Miscela Acqua - Glicole max. 50%
Filettatura standard	Rp - filettatura femmina, G - filettatura maschio
Pompa di ricircolo	Wilo Para Z ku 15-130/8-75/SC
Materiale, corpo valvola	Ottone EN 12165 CW617N
Materialie, isolante	Polipropilene Espanso EPP

LK 865 HydronicGroup H 125 DN 25 è un gruppo completo per la circolazione dell'acqua calda.

LK 865 HydronicGroup H 125 DN 25 comprende, fra l'altro, la pompa di ricircolo ad alta efficienza, una valvola miscelatrice, croce, pompa di ricircolo, isolamento, due termometri, kit di connessione e tre valvole di ritegno.

LK 551 HydroMix valvola miscelatrice ha un elemento termostatico per regolare la temperatura dell'acqua al valore desiderato. La valvola ha una funzione antiscottatura che chiude il flusso di acqua calda in caso che la fornitura d'acqua fredda non funzioni.

**TEKNILLISET TIEDOT**

Jännite	230 VAC 50/60 Hz
Tehonkulutus	10-75 W pumpun nopeudesta riippuen
Käyttölämpötila	Min. 5 °C/Maks. 100 °C
Ympäristön lämpötila	Min. 5 °C/Maks. 58 °C
Maks. käyttöpaine	1,0 MPa (10 bar)
Siirtoneste	Vesi - Glykolia maks. 50%
Kierrestandardi	Rp - sisäkierre, G - ulkokierre
Kiertovesipumput	Wilo Para Z ku 15-130/8-75/SC
Materiaali, venttiilipesä	Messinki EN 12165 CW617N
Materiaali, eriste	Paisutettu Polypropeeni EPP

LK 865 HydronicGroup H 125 DN 25 on täydellinen pumppuryhmä käyttöveden kiertoa varten.

LK 865 HydronicGroup H 125 DN 25 sisältää mm. tehokkaan kiertopumpun, shunttiventtiilin, ristiliittimen, eristeen, kaksi lämpömittaria, liitinsarjan ja kolme vastaventtiiliä.

LK 551 HydroMix -sekoitusventtiilissä on termostaattielementti, joka säätelee kylmän ja kuuman veden syöttöä niin, että saavutetaan haluttu lämpötila. Venttiilissä suojaustoiminto, joka sulkee kuuman veden tulon, jos kylmän veden tulo lakkaa.

**TEKNISK DATA**

Spänning	230 VAC 50/60 Hz
Effektförbrukning	10-75 W beroende av pumphastighet
Arbetstemperatur	Min. 5 °C/Max. 100 °C
Omgivningstemperatur	Min. 5 °C/Max. 58 °C
Max. arbetstryck	1,0 MPa (10 bar)
Media	Vatten - Glykolinblandning max. 50%
Gängstandard	Rp - invändig gänga, G - utvändig gänga
Cirkulationspump	Wilo Para Z ku 15-130/8-75/SC
Material, ventilhus	Mässing EN 12165 CW617N
Material, isolering	Expanderad Polypropylen EPP

LK 865 HydronicGroup H 125 DN 25 är en komplett pumpgrupp för varmvattencirkulation.

LK 865 HydronicGroup H 125 DN 25 består bland annat av högeffektiv cirkulationspump, en shuntventil, korsrör, isolering, två termometrar, koppelsats och tre backventiler.

LK 551 HydroMix blandningsventil har en termisk insats som reglerar tillförseln av både kall- och hetvatten så att önskad temperatur uppnås. Ventilen har ett skällningsskydd som stänger för inkommande hetvatten om kallvattentillförseln skulle upphöra.



LK 865 - PUMP CHARACTERISTICS

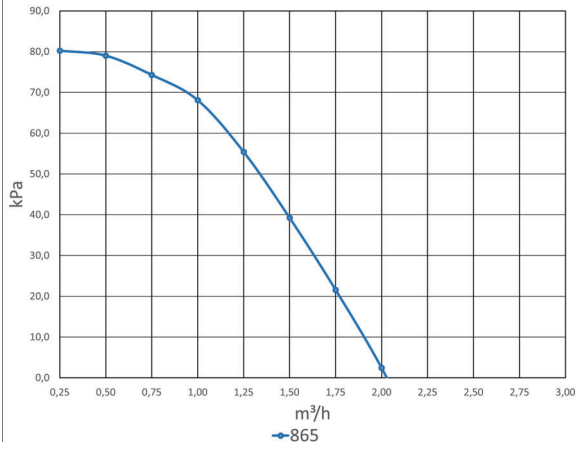

LK 865 - PUMP GROUP WITH DIRECT SUPPLY

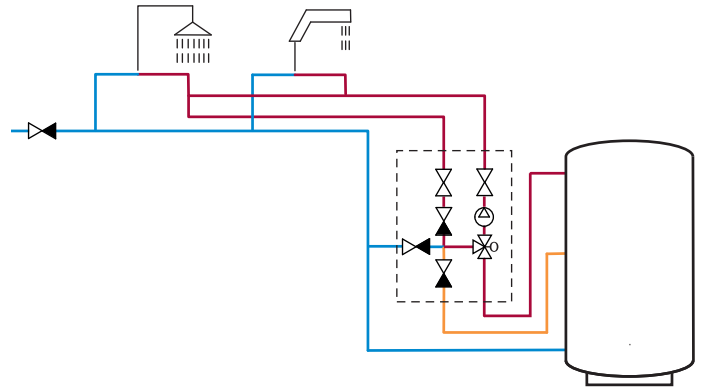

LK 865 - PUMP GROUP

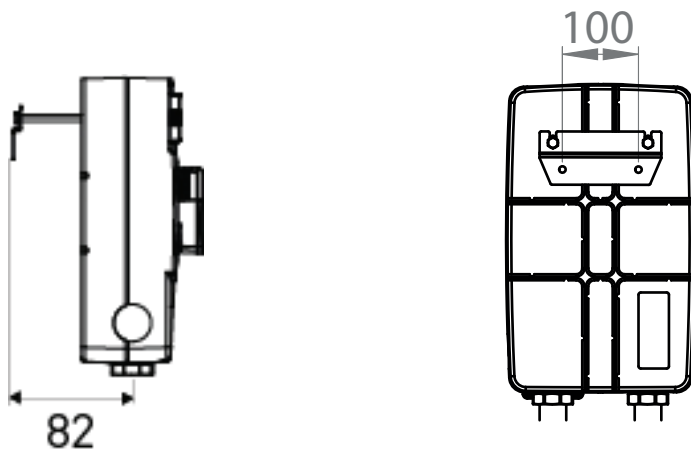
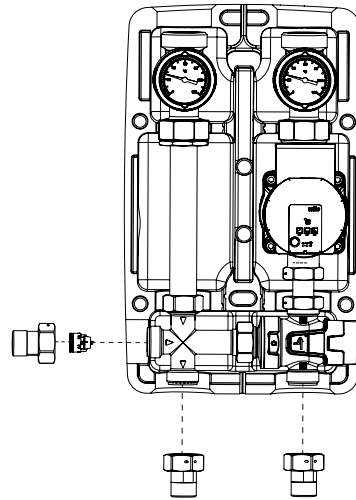
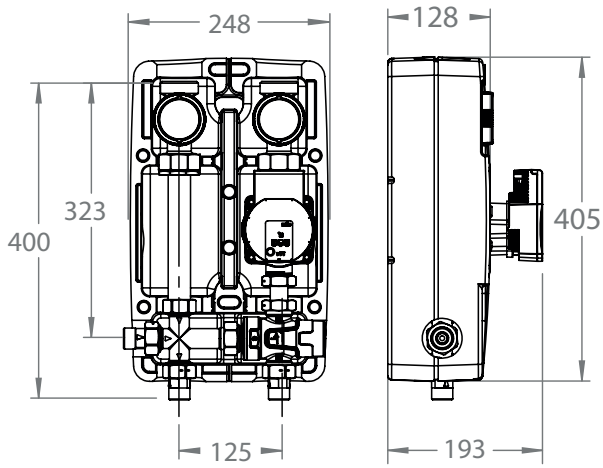

LK 865 - RIGHT

LK 865 - LEFT

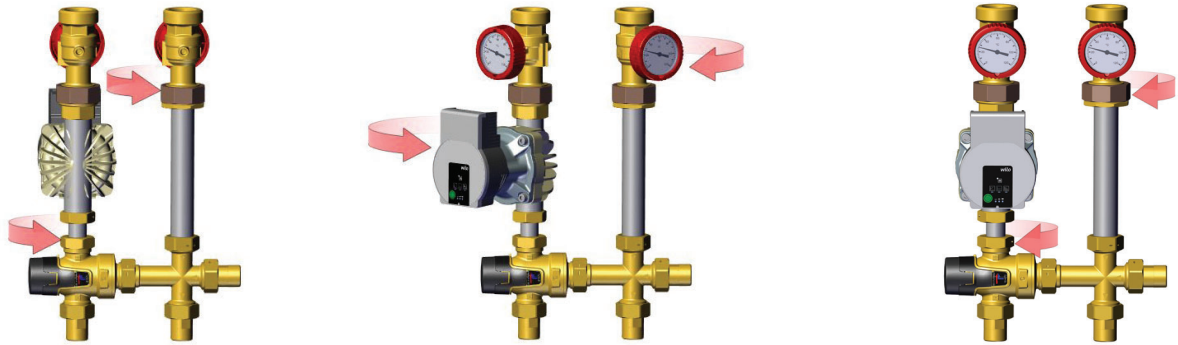
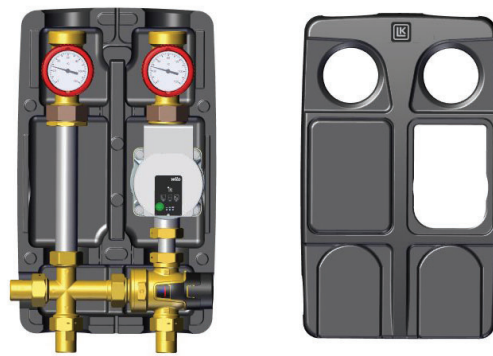
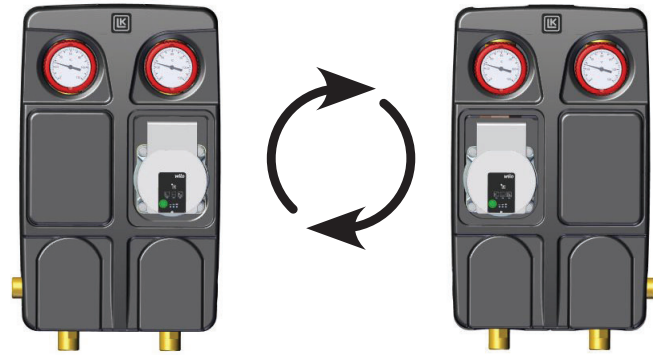

LK 865 - LEFT

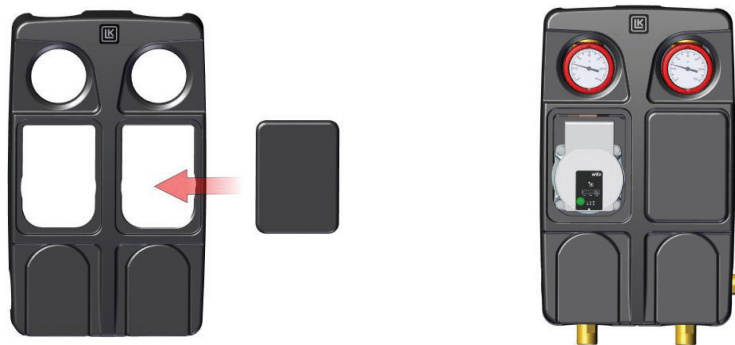

RESERVDLAR OCH TILLBEHÖR

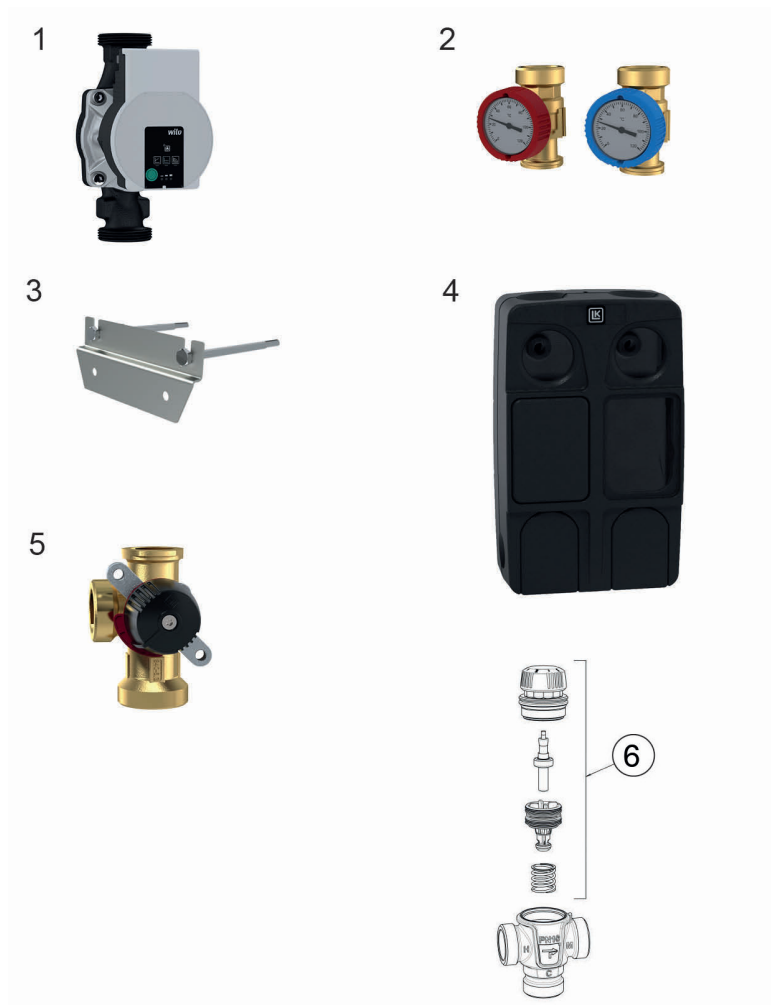

Article no.	Article	Position
187346	Wilo Para Z ku 15-130/8-75/SC Circulating pump   Umwälzpumpe   Circulateur   Pompa di ricircolo   Kiertovesipumppu   Cirkulationspumpe	1
187323	Ballvalve, blue   Kugelventil, Blau   Robinet à bille, bleu   Valvola a sfera, blu   Palloventtiili, sininen   Kulventil, blå	2
187324	Ballvalve, red   Kugelventil, rot   Robinet à bille, rouge   Valvola a sfera, rossa   Palloventtiili, punainen   Kulventil, rød	2
187325	Bracket   Konsole   Console   Collettore   Konsoli   Konsol	3
187326	EPP Insulation   EPP Isolierung   EPP Isolation   EPP Isolmento   EPP eriste   EPP Isolering	4
187327	Mixing Valve Kvs 6,3   Mischer Kvs 6,3   Vanne mélangeuse Kvs 6,3   Valvola michelatrice meccanica Kvs 6,3   Sekoitusventtiili Kvs 6,3   Shuntventil Kvs 6,3	5
187328	Mixing Valve Kvs 10   Mischer Kvs 10   Vanne mélangeuse Kvs 10   Valvola michelatrice meccanica Kvs 10   Sekoitusventtiili Kvs 10   Shuntventil Kvs 10	5
095349	551, 25 - 45 °C [Kvs 3.2-4.2] Repair kit   Einsatz   Kit de rép.   Kit di riparazione   Korjaussarja   Rep. sats	6
095350	551, 35 - 65 °C [Kvs 3.2-4.2] Repair kit   Einsatz   Kit de rép.   Kit di riparazione   Korjaussarja   Rep. sats	6

# Wilo-Para Quick start guide



## WILO-PARA SELF CONTROL / INSTALLATION

### One push-button

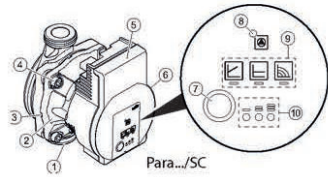

- 1 Pump housing with screwed connections
- 2 Glandless motor
- 3 Condensate drain openings (4x around circumference)
- 4 Housing screws
- 5 Control module
- 6 Rating plate
- 7 Green push button
- 8 Fault signal LED
- 9 Display for control mode ( $\Delta p-v$ ,  $\Delta p-c$ , N constant)
- 10 Display for speed setting (I, II, III)

### Electrical connection

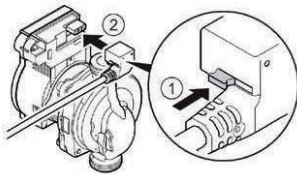

### Standard factory setting

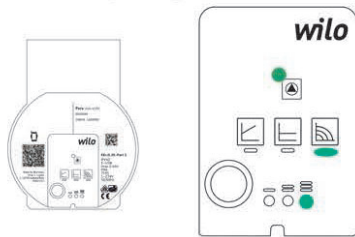

## WILO-PARA SELF CONTROL / SETTING

### Differential pressure variable $\Delta p-v$ (I, II, III)

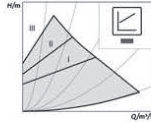

Recommended for two-pipe heating systems with radiators to reduce the flow noises at thermostatic valves.

### Constant differential pressure $\Delta p-c$ (I, II, III)

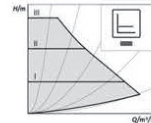

Recommended for underfloor heating or for large-sized pipes, applications without a variable pipe network curve (e.g. storage charge pumps) or single-pipe heating systems with radiators.

### Constant speed (I, II, III)

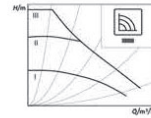

Recommended for systems with fixed system resistance requiring a constant volume flow and for replacement of AC pumps.

### Push to change the pump setting

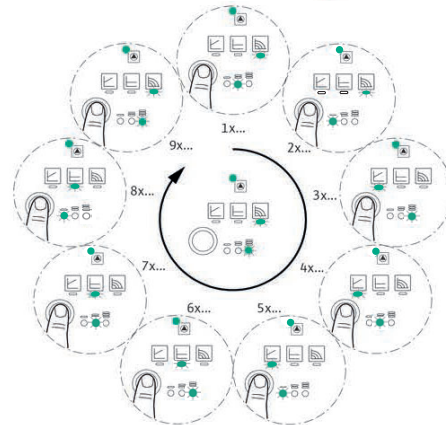

## WILO-PARA SELF CONTROL / SMART FUNCTIONS

### Air-venting mode

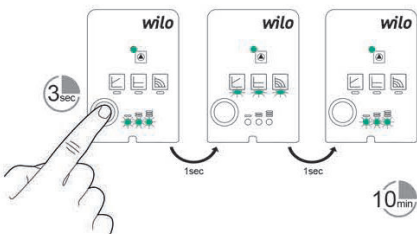

### Manual restart

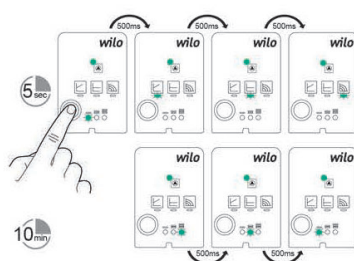

### Lock & unlock

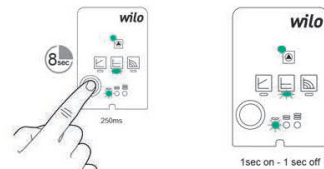





**LK ARMATUR AB**  
Garnisonsgatan 49  
SE-254 66 Helsingborg  
Info@lkarmatur.com  
lkarmatur.com